

# McLaughlin Bennett 5.0

with FORESTADENT

+17° +4° 1,0  
+10° +8° 1,4  
-7° +8° 0,8  
-7° 0° 0,8  
-7° 0° 1,2

-6° -6° 1,4  
-6° 0° 1,4  
-6° +3° 0,8  
-12° +2° 0,65  
-17° +2° 0,65

Slot .018" / Slot .022"



+17° +4° 1,0  
+10° +8° 1,4  
-7° +8° 0,8  
-7° 0° 0,8  
-7° 0° 1,2

-6° -6° 1,4  
-6° 0° 1,4  
-6° +3° 0,8  
-12° +2° 0,65  
-17° +2° 0,65

Slot .018" / Slot .022"





... the only philosophy which offers a comprehensive system – it includes a range of high quality brackets, precise information on where to place those brackets, and full information on arch form and force levels. All of this is backed up with best-selling textbooks.

**Contents:**

Changes and progress	3
The story so far	4
Important advances in 10 key areas	7
Q & As on mechanics	12
Continuing education	13
Brackets and tubes	14
Archwires	15

## If we are not making changes, we are not making progress.

The work of Dr. Lawrence F. Andrews in the 1970s changed everything. The emphasis moved away from wire bending, and two things became essential for good treatment mechanics – bracket positioning and bracket quality. In the 1980s and 1990s we developed our treatment philosophy with Dr. Hugo Trevisi and we released it at the AAO in Philadelphia in 1997. In time, it became the most widely used treatment method in the world, but things have moved on since then. We have continued to develop and improve the treatment method and here we document some of the important changes we have made.

It has been our life's work to develop an 'ideal' treatment system. McLaughlin Bennett 5.0 is the latest version of this, and it is fully described in our recent textbook, 'Fundamentals of Orthodontic Treatment Mechanics'.

The aim has been to 'keep the best and improve the rest' and you will see important advances in 10 key areas:

1. Indirect bonding
2. Bracket accuracy
3. Better working wires
4. Reducing decalcification
5. Anchorage support
6. A focus on the airway
7. Efficiency in enamel reduction
8. Improved versatility
9. The 'Progress Review'
10. Finishing protocols

You may want to consider introducing some of these improvements, and we look forward to the pleasure of working with you at the courses.

John Bennett & Rick McLaughlin

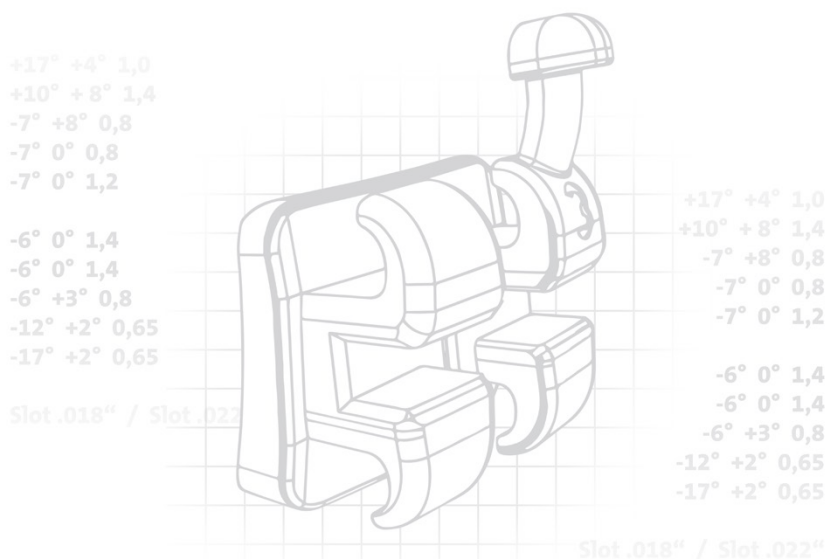

## **The 1970s and the work of Andrews**

Andrews released his landmark 'Six Keys' paper in 1972 and introduced the SWA, based on his research. The orthodontic world was changed forever.

## **1980 – 1989 The treatment mechanics years**

We described our work on light continuous forces and sliding mechanics in a series of papers, the first appearing in 1989.

## **1993 The start of book publishing**

Our first book – 'Orthodontic Treatment Mechanics and the Preadjusted Appliance' – explained the mechanics in more detail and included a selection of treated cases.

## **1990 – 1996 The bracket design years**

The SWA brackets were redesigned, keeping all the advantages, but dealing with the apparent shortcomings. This involved less tip, more torque control, and a mass of detail refinements. Also, versatility was recommended, to simplify mechanics in a range of treatment situations.

## **1997 The release of the second book**

'Orthodontic Management of the Dentition with the Preadjusted Appliance' was released at the AAO meeting in Philadelphia. It defined the bracket specifications which have stood the test of time, and continue to be effective 20 years later.

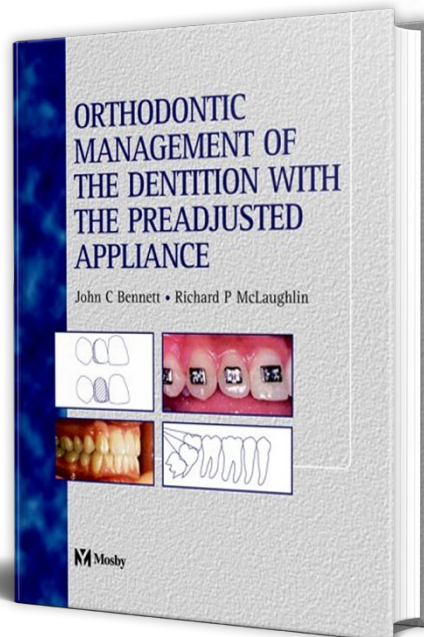

This practical, highly illustrated guide presents an innovative, organized approach to essential topics in orthodontics such as crowding, spacing, tooth size discrepancies, and management of common ectopic eruption problems and impactions. Its unique approach focuses on the treatment mechanics of each individual tooth involved, rather than the dentition as a whole.

## 1997 – 2001 Refining the treatment system

Hundreds more cases were treated during these four years, refining the recommended mechanics and brackets.

## 2001 The release of the third book

The definitive Book 3 was published – ‘Systemized Orthodontic Treatment Mechanics’. There were more than 20,000 copies in English, and it was published in at least 12 other languages. It became the standard mechanics text in many universities.

## 2005 – 2008 The confused years

This was a confused period in orthodontics, when arch expansion was once again being promoted as a method of managing crowding, with no clear evidence that this was beneficial for patients or orthodontists. For several years this undermined the values and fabric of the orthodontic specialty.

## 2014 The release of the fourth book and McLaughlin Bennett 4.0

‘Fundamentals of Orthodontic Treatment Mechanics’ was released in March 2014 (See page 12). It clears away the confusion of recent years, and defines an improved treatment philosophy for a new generation of orthodontists. It is available in multiple languages.

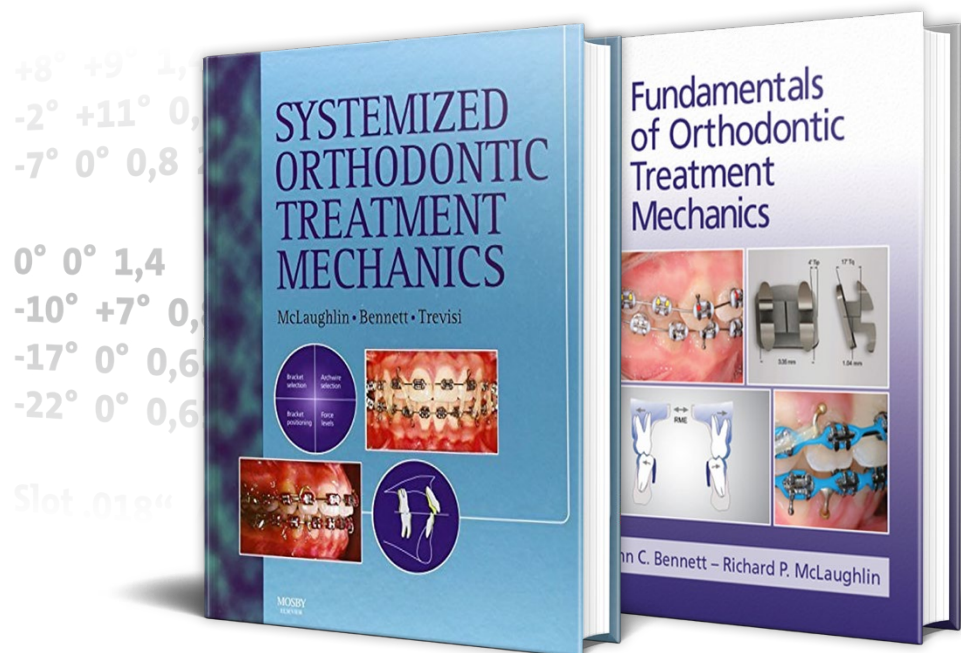

A valuable information source for orthodontists at all levels who are seeking to provide high quality care. For students, looking for a concise understanding of modern treatment methods, it offers a clear pathway forward.



Simplicity  
—  
the ultimate  
sophistication.

*Leonardo da Vinci*

## 1. Indirect bonding

### The importance of accurate bracket positioning

After the introduction of the SWA in the 1970s, based on Andrews' research, everything changed. Suddenly bracket positioning became all-important. In the days of standard edgewise, the best results came from the best wire benders. With the pre-adjusted edgewise the best results came from those who could achieve the most accurate bracket positioning, because everything was built into the brackets.

The original concept was to position the brackets in the middle of the clinical crown. However, it proved difficult to get vertical accuracy by 'eyeballing', and in the 1990s gauges were recommended.<sup>1</sup>

In the 2000s there has been a move to combine the use of gauges with indirect bonding systems (IDBS). This brings benefits to patients and orthodontists alike. Bracket positioning is more accurate, less 'doctor time' is needed, and the patient has a better experience when setting up the case. More details are on page 74 of 'Fundamentals of Orthodontic Treatment Mechanics'.



Picture: Indirect bonding

## 2. Bracket accuracy

### The need for excellent brackets

In the early years with the treatment method, the 'full-size' development brackets were accurately manufactured in Munich. German technology was available, and a milling process was used as a precise manufacturing method, to create accurate brackets for proper tooth control. However, the brackets were rather large, and milling was not an efficient manufacturing process. Experience has shown that it is difficult to be cost effective when making brackets and tubes by milling.

Accordingly, in the 1990s there came a demand for smaller brackets and an efficient manufacturing process. This brought a move to mid-size brackets, and a change to manufacture by metal injection moulding (MIM).

Brackets need to be precisely manufactured, or treatment becomes less efficient and more wire bending will be required. MIM can be a good production method, but only if there is great attention to quality control. Technical expertise is needed, along with good quality control, and in the past, many bracket types have been shown to be inaccurate.<sup>2</sup>

Forestadent is at the forefront of MIM technology. The company has its origins in the watch industry and is renowned for precision. We have complete confidence in the Forestadent Mini Sprint range of high quality brackets and tubes, and have no hesitation in recommending them. We appreciate Forestadent's support for dental education worldwide.

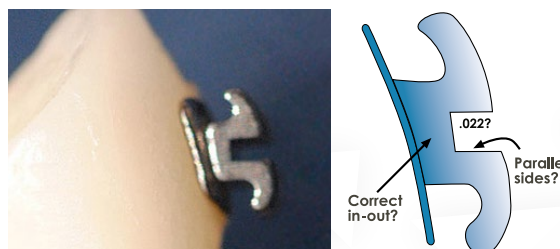

Pictures: Accuracy and quality control are essential.

<sup>1</sup> McLaughlin RP, Bennett JC. Bracket placement with the preadjusted appliance. J Clin Orth 1995; 29: 302-11.

<sup>2</sup> Cash A C, Good S A, Curtis R V, McDonald F. 2004 An evaluation of slot size in orthodontic brackets – are standards as expected? Angle Orthod. 74: 450-453

## 3. Better working wires

### Control of overbite and torque

In recent years there have been advances in the quality and accuracy of steel wires, which is a big step forwards. Wires with increased spring temper bring new standards of control for overbite, torque, and arch form, and they are diamond drawn for a smooth finish. The soldered ball hooks perform better than the earlier 'posts'. The new type of hook is of solid brass with a swaged ball end. It is more comfortable for the patient than the previous bare soldered hooks, and placement of elastics is easier.

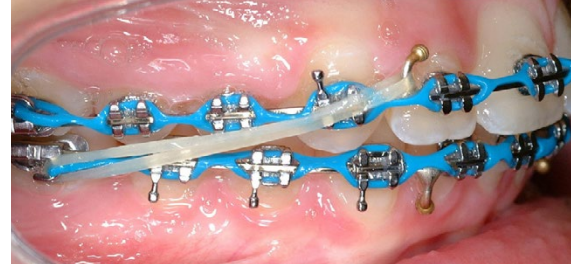

Picture: The latest wires help control of overbite, torque, and arch form.

## 4. Reducing decalcification

### Sealing and protecting enamel against white spot lesions (WSLs)

Orthodontic treatment can cause plaque accumulation around the brackets and increase the risk of enamel white spot lesions<sup>3</sup>, but steps can be taken to reduce this risk.

The whole labial surface of the tooth enamel can be etched, instead of the traditional etching of a small area below the bracket base. After rinsing and drying, the whole labial surface can then be sealed, as a measure to reduce the risk of demineralisation.

Several years of use indicate that there are benefits to using a sealant in this way, but it will be some time before the studies appear to confirm this. More details are on pages 72 and 73 of 'Fundamentals of Orthodontic Treatment Mechanics'.

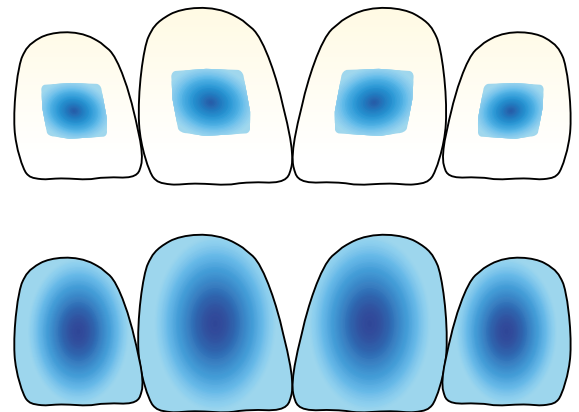

Picture: Etching of the whole labial surface before sealing, to reduce the risk of enamel demineralization.

<sup>3</sup> Sigurd Hadler-Olsen, Kristin Sandvik, Mohammad A. El-Agroudi, and Bjørn Øgaard 2012 The incidence of caries and white spot lesions in orthodontically treated adolescents with a comprehensive caries prophylactic regimen— a prospective study Eur J Orthod 34(5): 633-639



## 5. Anchorage support

### TADs and plates

It is easy to combine TADs or plates with the treatment method, and there is no need to change the appliance or the mechanics. Mini screws can be used at various stages in the treatment, if absolute anchorage is needed. They can serve to anchor molars during levelling and aligning, or they can support the use of elastics or coil springs during sliding mechanics, but there are concerns about failure rates, which have recently been reported as 22% (maxilla) and 31% (mandible).<sup>4</sup>

Surgical plates are an effective option. They are normally fitted by oral surgeons, because the placement technique is more invasive than with TADs, and a surgical flap is required. They are very reliable, with a failure rate which is less than TADs.<sup>5</sup>



Picture: Surgical plates are effective and reliable.

## 6. A new focus on the airway

### Functional appliances and RME

As orthodontists we have a responsibility to maintain or improve the airway during treatment, and there is an increased focus on this. It is a service to the patient to maintain an awareness of airways and sleep disorders, and make enquiries about this during history taking and clinical examination. If there is a positive response to these questions, then referrals are made for evaluation. If rapid maxillary expansion or functional appliances<sup>6</sup> are included in the treatment plan, this may be expected to produce some airway improvement, along with the orthodontic changes. Conversely, airway consideration is needed to avoid adverse changes when planning Class III surgical cases.

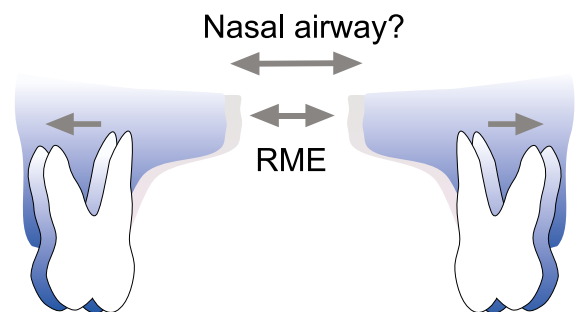

Picture: RME or functional appliances can help airway improvement.

<sup>4</sup> Bearn DR, Alharbi F 2015 British Orthodontic Society national audit of TADs: report of the first thousand placed. J Orthod. 42 214-219

<sup>5</sup> De Clerck EB, Swennen GRJ. 2011 Success rate of miniplate anchorage for bone anchored maxillary protraction. Angle Orthod. 81:6 1010-1013

<sup>6</sup> Bennett J. 2006 Orthodontic management of uncrowded Class II division one malocclusions in children. Mosby ISBN-13 07234 34263

## 7. Efficiency in enamel reduction

### Relief of crowding in non-extraction cases. Managing situations where the teeth do not fit.

Inter proximal enamel reduction (IPR) is becoming increasingly important in orthodontics, and it is often the method of choice to deal with mild crowding, especially in adult cases. This brings a new focus on the need for efficiency. Chapter 9 in the new book discusses appropriate techniques and explains that the procedure is safe, if properly carried out.<sup>7</sup> It gives recommendations for the amount of enamel which may be safely removed.

Careful management of tooth size is needed in many cases to reach an ideal occlusion. In the closing stages, after correction of incisor torque, overbite and overjet, spacing is often seen in one arch (more frequently the upper) due to a tooth size discrepancy. This is managed by enamel reduction or composite build-up, or by a combination of these two procedures, and efficient IPR is needed.



Picture: Interproximal enamel reduction.

## 8. Improved versatility

### New versatility options

Versatility reduces the need for wire bending and improves treatment efficiency. New options are described in chapter five and these include:

- It can be helpful to invert lower incisor brackets (to give +6° torque) in some Class III cases to prevent unwanted retroclination of lower incisors. This can also be useful in cases where molar anchorage loss is needed or where a single lower incisor is proclined.
- In some Class III treatments it is helpful to switch left and right lower canine brackets. This changes the tip from +3° to -3° and can make the mechanics easier.
- For good root control with buccally ectopic upper canines, the -7° torque bracket is not really suitable, and works better when inverted to give the +7° option, which guides the root into cancellous bone.

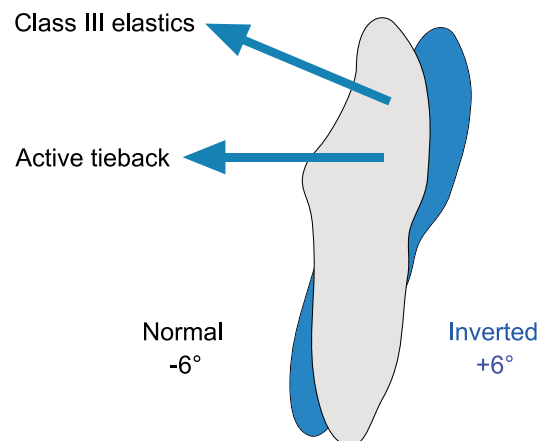

Picture: It is helpful to invert the lower incisor brackets in some cases.

<sup>7</sup> Zachrisson BU, Nyøygard L, Mobarak K 2007 Dental health assessed more than 10 years after interproximal enamel reduction of mandibular anterior teeth. Am J Orthod Dentofacial Orthop; 131:162-9 | Zachrisson BU, Minster L, Øgaard B, Birkhed D 2011 Dental health assessed after interproximal enamel reduction: Caries risk in posterior teeth. Am J Orthod Dentofacial Orthop 139:90-98

## 9. The 'Progress Review'

### Easier treatment in the closing stages

During treatment, and after the main tooth movements have been achieved, a long 'progress review' appointment is recommended. The timing of this varies from case to case, and it is informally known as 'Clean up time'. Bracket positions and other aspects of the treatment are carefully checked, sometimes with the help of radiographs and / or a set of progress models. Errors are corrected as necessary, and the ongoing needs of the case are recorded. This simple step makes finishing easier and often shortens the treatment time.

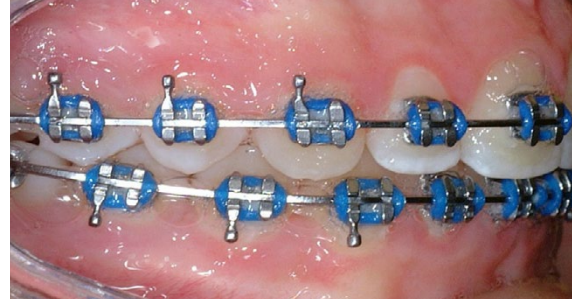

Picture: The Progress Review helps finishing.

## 10. Finishing protocols

### Settling the case

The final stages of an orthodontic treatment can be a challenging time for the orthodontist, and this was recognised at an early stage.<sup>8</sup> To improve effectiveness, and avoid needless appointments, an improved protocol is recommended for the finishing stages. It can be managed in three steps:

- The correction of errors made before finishing
- Overcorrection of key features of the malocclusion
- Case settling

When finishing the case, it is important to minimise negative changes while the teeth settle. 'Frequent options' are available and are described in detail, to be used for upper and lower arch settling. They are used in different combinations, depending upon the needs of the case.



Picture: 'Up and Down' elastics during finishing.

<sup>8</sup> McLaughlin RP, Bennett JC. Finishing and Detailing with the Preadjusted Appliance System. 1991 Journal of Clinical Orthodontics, Vol. 25, pp. 251-264

## **Should I choose .018 or .022 slot size?**

The mechanics work better with .022.

## **I like the idea of the 'Progress Review'. At what stage is it done?**

There is no fixed stage. In routine non-extraction cases we often schedule the Progress Review when we are ready to move into working wires. In more challenging cases, where major tooth movements are needed, or in extraction cases, the Progress Review will often be helpful later in the treatment. This may be towards the end of space closure, or after the incisor relationship has been corrected.

## **The lower incisor brackets seem a little thick. Is this OK?**

Most brackets currently available do not have the correct in-out. The in-out values of our brackets appear a little thick, but are based on Andrews' research. In almost all cases they deliver ideal alignment without the need for first order bends, particularly in the lower labial segment.

## **You are using very accurate brackets. Does the improved precision bring any disadvantages?**

It helps the progress of the treatment and the outcome to work with precise brackets! We find there is a need for care in three clinical situations.

1. In a few cases there may be a tendency for upper and lower incisor roots to be a little forward.
2. In cases with an instanding upper lateral incisor, where the bracket has been inverted, there is a risk of too much over-correction. In situations (1) and (2) the remedy is to drop down from .019/.025 to a smaller wire, such as .017/.022.
3. In some non extraction cases doctors choose to use zero torque brackets for the lower incisors. This is a useful option where patients decline to have IPR, or where it is not carried out adequately.

## **I am planning to switch to indirect bonding system (IDBS). Are there any tips?**

It is definitely a good move to make the switch. It is best to work with a colleague who is experienced with IDBS, but there is some information on YouTube. There is no doubt that indirect bonding has become easier with the newer materials.

## **Should I order brackets with hooks on canines and/or premolars?**

We are currently not advocating hooks on premolar brackets, but many orthodontists find hooks are useful on canine brackets. The  $-7^\circ$  torque upper and  $-6^\circ$  torque lower canine brackets are sometimes inverted, depending on the needs of the case, and in this situation it is necessary to cut off the hooks and smooth the metal after cutting.

## **Do I need to order full size second molar tubes?**

Surprisingly, we find that the mini tubes work well in almost all clinical situations.

## **I like to use the new high tensile steel working wires with ball hooks. Any advice about using them?**

They seem to perform better and bring advantages in torque control, sliding mechanics, and overbite correction. There is advice on pages 89 to 92 of the new book, including the five factors in overbite control. In cases with a deep bite the working wires are used 'flat' for the first two or three months and we find there is seldom a need to add 'anti-Spee' if the rules are followed.

## The new book in nine editions

### **Fundamentals of Orthodontic Treatment Mechanics**

John C. Bennett & Richard P. McLaughlin

A hardcover textbook with 300 pages, 14 chapters, and more than 900 color illustrations and line drawings. This is a valuable information source for orthodontists at all levels who are seeking to provide high-quality care, and for students who are looking for a concise understanding of modern treatment methods.

Available in: English, Romanian, Italian, Spanish, Japanese, Turkish, Korean, Ukrainian, Polish

(Portuguese and Chinese in preparation)

Please contact Forestadent for sources of the book.

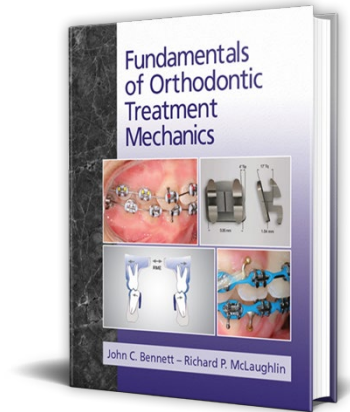

## The two-year program

The popular McLaughlin two-year program is held in San Diego, at an all-new and expanded facility in the new practice.

There are six sessions (three per year) over a two year period [www.mclaughlince.com](http://www.mclaughlince.com). It teaches an accurate and efficient approach to patient care using diagnostics, treatment planning, and case management, and is intended for certified orthodontists who want to extend their knowledge of the treatment method. Each session lasts 3 or 4 days and includes a case presentation, discussion, and hands-on segment.



## The international courses

Our courses feature many stage-by-stage treated cases to pass on new ideas and show the ease of the mechanics. Through the courses we keep in touch with colleagues worldwide and receive feed-back and suggestions. This helps in the development of the concept, and we gratefully acknowledge the contributions from orthodontic colleagues. Courses are available at all levels, and this image shows a group of 200 orthodontists and postgraduate students attending Dr. Bennett's program in Madrid, May 2014.



## Mini Sprint® II Brackets McLaughlin Bennett 5.0

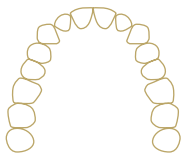

Optimized arch form through clinically proven bracket values. Adjusted In/Out values for better clinical results.



Better comfort through lowered hooks with flatter design and increased space between tie wings and pad.



Anatomically curved hook base for optimal bonding results.

Maxillary					Slot .018"		Slot .022"	
Tooth	Torque	Angulation	In/Out	Rotation	Order No.		Order No.	
					Right	Left	Right	Left
<b>1</b> Centrals	+17°	+4°	1,05	-	780T0103	779T0103	780T0101	779T0101
<b>2</b> Laterals	+10°	+8°	1,25	-	780T0203	779T0203	780T0201	779T0201
<b>3</b> Cuspids	-7°	+8°	0,6	-	780T0313	779T0313	780T0311	779T0311
	-7°	+8°	0,6	-	780T0303	779T0303	780T0301	779T0301
<b>3</b> Cuspids + hook	0°	+8°	0,6	-	780T0333	779T0333	780T0331	779T0331
	0°	+8°	0,6	-	780T0323	779T0323	780T0321	779T0321
<b>4</b> Bicuspids	-7°	0°	0,8	-	780T0413	779T0413	780T0411	779T0411
	-7°	0°	0,8	-	780T0403	779T0403	780T0401	779T0401
<b>5</b> Bicuspids + hook	-7°	0°	0,8	-	780T0413	779T0413	780T0411	779T0411
	-7°	0°	0,8	-	780T0403	779T0403	780T0401	779T0401

Mandibular					Slot .018"		Slot .022"	
Tooth	Torque	Angulation	In/Out	Rotation	Order No.		Order No.	
					Right	Left	Right	Left
<b>1</b> Centrals	-6°	0°	1,3	-	780T1203	780T1203	780T1201	780T1201
<b>2</b> Laterals	-6°	0°	1,3	-	780T1203	780T1203	780T1201	780T1201
<b>3</b> Cuspids	-6°	+3°	0,6	-	780T1413	779T1413	780T1411	779T1411
	-6°	+3°	0,6	-	780T1403	779T1403	780T1401	779T1401
<b>3</b> Cuspids + hook	0°	+3°	0,6	-	780T1433	779T1433	780T1431	779T1431
	0°	+3°	0,6	-	780T1423	779T1423	780T1421	779T1421
<b>4</b> Bicuspids	-12°	+2°	0,65	-	780T1513	779T1513	780T1511	779T1511
	-12°	+2°	0,65	-	780T1503	779T1503	780T1501	779T1501
<b>5</b> Bicuspids + hook	-17°	+2°	0,65	-	780T1613	779T1613	780T1611	779T1611
	-17°	+2°	0,65	-	780T1603	779T1603	780T1601	779T1601

### Cases

Maxillary Cuspids: 0° Torque; Mandibular Cuspids: 0° Torque

Maxillary Cuspids: -7° Torque; Mandibular Cuspids: -6° Torque

Variation	Slot .018"			Slot .022"			Slot .018"			Slot .022"		
	1	5	10	1	5	10	1	5	10	1	5	10
	706T1060	706T1061	706T1062	706T1069	706T1070	706T1071	706T1031	706T1032	706T1033	706T1046	706T1047	706T1048
3	706T1063	706T1064	706T1065	706T1072	706T1073	706T1074	706T1036	706T1037	706T1038	706T1051	706T1052	706T1053
3-5	706T1066	706T1067	706T1068	706T1075	706T1076	706T1077	706T1041	706T1042	706T1043	706T1056	706T1057	706T1058

## Tulip buccal tubes McLaughlin Bennett 5.0



OK / Maxillary	Tooth	Torque	Angulation	Distal Offset	Slot	on large pad	
						right	left
	76   67	-14°	-	10°	.018" x .028"	743T0744	742T0744
						.022" x .028"	743T0742
UK / Mandibular	6   6	-20°	-	0°	.018" x .028"		743T1714
					.022" x .028"	743T1712	742T1712
	7   7	-10°	-	0°	.018" x .028"	742T0724	743T0724
					.022" x .028"	742T0722	743T0722

## Archwires McLaughlin Bennett 5.0

description	Tapered-form		Ovoid-form		Square-form		profile	ø inch
	Order No. Maxillary	Order No. Mandibular	Order No. Maxillary	Order No. Mandibular	Order No. Maxillary	Order No. Mandibular		
<b>McLaughlin Bennett 5.0 Nickel Titanium - Heat Activated</b>	208H0835	208H0935	208H1835	208H1935	208H2835	208H2935		.014"
	208H0840	208H0940	208H1840	208H1940	208H2840	208H2940		.016"
	208H2040	208H2140	208H3040	208H3140	208H4040	208H4140		016" x .022"
	208H2044	208H2144	208H3044	208H3144	208H4044	208H4144		.017" x .025"
	208H2048	208H2148	208H3048	208H3148	208H4048	208H4148		.019" x .025"
<b>McLaughlin Bennett 5.0 Stainless Steel</b>	202-0835	202-0935	202-1835	202-1935	202-2835	202-2935		.014"
	202-0840	202-0940	202-1840	202-1940	202-2840	202-2940		.016"
<b>McLaughlin Bennett 5.0 Stainless Steel Heat Treated</b>	202H0845	202H0945	202H1845	202H1945	202H2845	202H2945		.018"
	202H0850	202H0950	202H1850	202H1950	202H2850	202H2950		.020"
	202H2048	202H2148	202H3048	202H3148	202H4048	202H4148		.019" x .025"

All archwires are supplied as package of 10 pieces.

## Archwires Ball Posted McLaughlin Bennett 5.0

description	Tapered-form		Ovoid-form		Square-form		mm	profile	ø inch
	Order No. Maxillary	Order No. Mandibular	Order No. Maxillary	Order No. Mandibular	Order No. Maxillary	Order No. Mandibular			
<b>McLaughlin Bennett 5.0 Stainless Steel Ball Posted</b>	-	209T2448	-	209O2448	-	209S2448	24		.019" x .025"
	-	209T2648	-	209O2648	-	209S2648	26		
	-	209T2848	-	209O2848	-	209S2848	28		
	209T3048	-	209O3048	-	209S3048	-	30		
	209T3248	-	209O3248	-	209S3248	-	32		
	209T3448	-	209O3448	-	209S3448	-	34		
	209T3648	-	209O3648	-	209S3648	-	36		
	209T3848	-	209O3848	-	209S3848	-	38		
	209T4048	-	209O4048	-	209S4048	-	40		
<b>McLaughlin Bennett 5.0 Stainless Steel Ball Posted</b>	-	209T2444	-	209O2444	-	209S2444	24		.017" x .025"
	-	209T2644	-	209O2644	-	209S2644	26		
	-	209T2844	-	209O2844	-	209S2844	28		
	209T3044	-	209O3044	-	209S3044	-	30		
	209T3244	-	209O3244	-	209S3244	-	32		
	209T3444	-	209O3444	-	209S3444	-	34		
	209T3644	-	209O3644	-	209S3644	-	36		
	209T3844	-	209O3844	-	209S3844	-	38		
	209T4044	-	209O4044	-	209S4044	-	40		

All archwires are supplied as package of 10 pieces.

*FORESTADENT (Germany)*

*Bernhard Förster GmbH  
Westliche Karl-Friedrich-Str. 151  
D-75172 Pforzheim*

*Phone: +49 (0) 7231 459-0*

*Fax: +49 (0) 7231 459-102*

*info@forestadent.com*

*www.forestadent.com*